

Wheel Diverter

Wheel Diverter modules redirect conveyed product using a series of simultaneously swiveling rollers. Offered in bi-directional and tri-directional configurations, they can be easily integrated with Motorized Powered Roller and/or Belt Conveyor modules to provide effective product sortation or transfer. Wheel Diverter modules are configured with individually powered roller zones that only run when product is detected by photo-eye sensors.

Technical Data:

Widths: <ul style="list-style-type: none"> Nominal Widths (NW) offered are 19", 25", 32" and 37" Available Between Frames (BF) widths are 15", 21", 28" and 33" 	Configuration: <ul style="list-style-type: none"> Bi-directional- One spur bed mounted at 30° or 45° Tri-Directional- Two spur beds mounted at 30° or 45° 	Rollers: <ul style="list-style-type: none"> 1.9" diameter, 16 gauge galvanized, single and double grooved, carrying rollers with 7/16" hex axles Roller spacing in 3" increments as a standard
Drive Rollers: <ul style="list-style-type: none"> 24 Volt DC brushless powered rollers w/ external motor drive cards 1.9" diameter, 7/16" hex axle 	Speed: <ul style="list-style-type: none"> Variable increments ranging from 55 to 237 feet per minute 	Load: <ul style="list-style-type: none"> 100 lbs per linear foot maximum Contact NACI for larger load requirements
Frame/Length: <ul style="list-style-type: none"> 7¼" deep formed 12 gauge steel channel Standard bed length is 60" Powder coated NACI Blue as a standard 	Drive Transfer: <ul style="list-style-type: none"> Parallel shaft AC gear motor, 115V, 50/60Hz 15" minimum gap between product Sort at rates up to 60 packages a minute 	Supports: <ul style="list-style-type: none"> Optional floor or ceiling supports available

Features:

- Non-Contact Accumulation
- Quiet Operation
- Easy to Maintain
- Safe 24V DC Operation
- Low Energy Consumption
- Plug and Play Design
- Reduced Installation Time

Applications:

- Transportation
- Sortation

Options:

- Custom Widths
- Flexible Number of Transfer Rollers
- Floor/ Ceiling Supports
- 30° or 45° Divert Angle
- Bi- or Tri-Directional

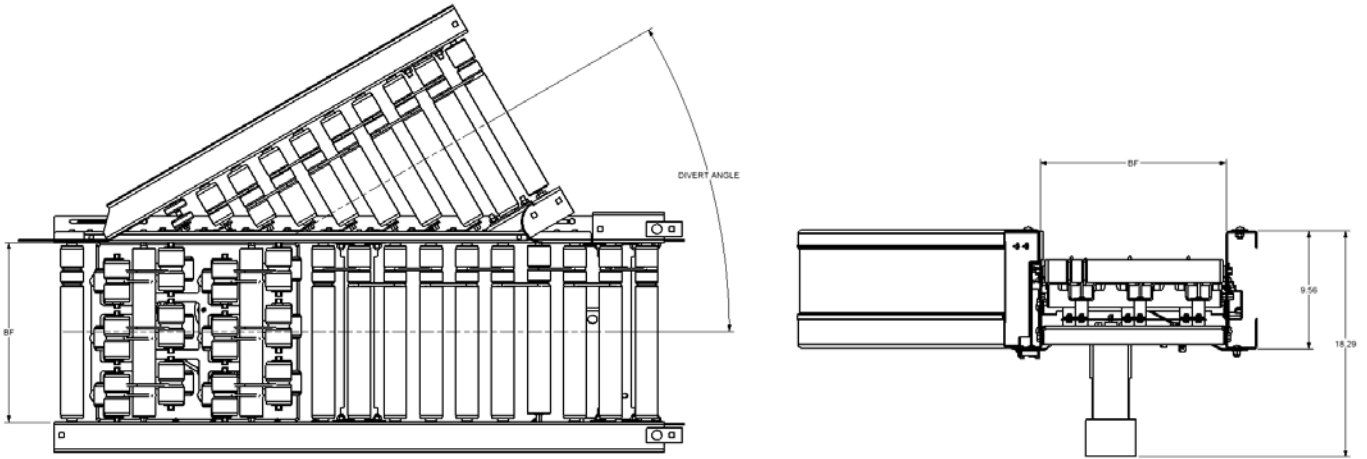

Bi-Directional

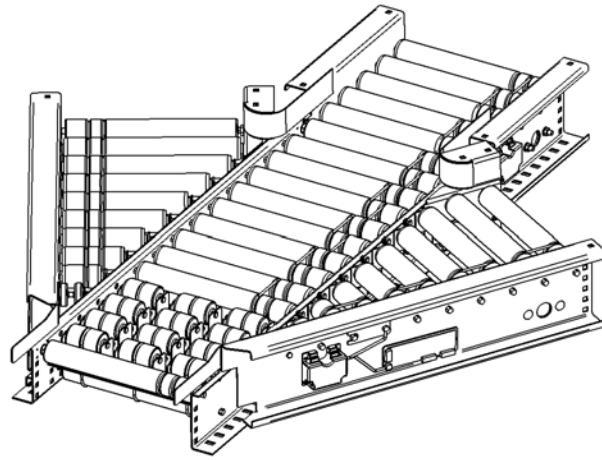

Tri-Directional

