

# Universal Sorter

Universal Sorter provides the ability to sort a diverse range of products on the same sorter. The Universal Sorter is designed to process products like hard sided packages, soft sided objects, sacks with tie cords and tags, tires or various small items simultaneously. The sorter is ideal for items typically considered non-conveyable on numerous standard sorters. The Universal Sorter uses electric pushers to divert product 90° from the sortation conveyor to powered or gravity run-out conveyors. The sorter will process up to 75 items per minute on conveyor running up to 250 feet per minute. The sorter capacity will vary depending on the size and weight of the product.

## Technical Data:

<p><b>Configurations:</b></p> <ul style="list-style-type: none"> <li>▪ In-Line – Single straight conveyor sorting to the left, right or both sides</li> <li>▪ Recirculating – Two parallel conveyors connected by 180° curves that can sort on both conveyors</li> </ul>	<p><b>Standard Widths:</b></p> <ul style="list-style-type: none"> <li>▪ Nominal Widths (NW) offered are 18", 24", 30" and 36"</li> <li>▪ Additional widths are available upon request</li> </ul>	<p><b>Sorter Capacity:</b></p> <ul style="list-style-type: none"> <li>▪ Sorts up to 75 pieces per minute on conveyor running at 250' per minute</li> <li>▪ Sorts products at least ½" high and up to 72' long</li> <li>▪ Capacity will vary depending on product</li> </ul>
<p><b>Live Load Capacity:</b></p> <ul style="list-style-type: none"> <li>▪ Up to 100 lbs per object depending on the sort rate required and system design</li> <li>▪ Up to 38 pounds per linear foot of conveyor</li> </ul>	<p><b>Diverter:</b></p> <ul style="list-style-type: none"> <li>▪ Electric pusher diverter is offered as the standard (2 sizes are available)</li> <li>▪ Pneumatic pusher diverter is available</li> <li>▪ Anti-snap pusher blade design</li> </ul>	<p><b>Drive:</b></p> <ul style="list-style-type: none"> <li>▪ Center or head end drive</li> <li>▪ Direct or indirect mounting</li> <li>▪ 6" to 10" urethane lagged drive pulley</li> <li>▪ Manual take-up as standard; automatic take-up available</li> </ul>
<p><b>Sorter Conveyor:</b></p> <ul style="list-style-type: none"> <li>▪ Slider Bed Conveyor is provided as the standard</li> <li>▪ Belt-On-Roller and Belt Driven Live Roller Conveyor are available options</li> </ul>	<p><b>Run-Out Conveyor:</b></p> <ul style="list-style-type: none"> <li>▪ Various lengths with widths up to 48" standard</li> <li>▪ Motorized Powered Roller; Limited Pressure Roller Accumulation and Gravity Conveyor are available options</li> </ul>	<p><b>Induction Options:</b></p> <ul style="list-style-type: none"> <li>▪ Meter Belt Conveyor</li> <li>▪ Slider Bed Conveyor</li> <li>▪ Belt-On-Roller Conveyor</li> <li>▪ Belt Drive Live Roller</li> <li>▪ Motorized Powered Roller</li> </ul>

### Features:

- Economical Design
- Medium Rate
- Customizable
- Wide Product Range
- Quiet/ Safe Operation
- Low Maintenance

### Applications:

- Non-Conveyables
- Shipping Sortation
- Receiving Sortation
- Sorting Trays, Tubs and Totes
- Sorting Packages

### Options:

- Pneumatic Diverters
- Extended Run-Outs
- Wide Run-Outs (to 6 ft)
- Number of Inductions
- Number of Diverts
- Supports/ Side Guards

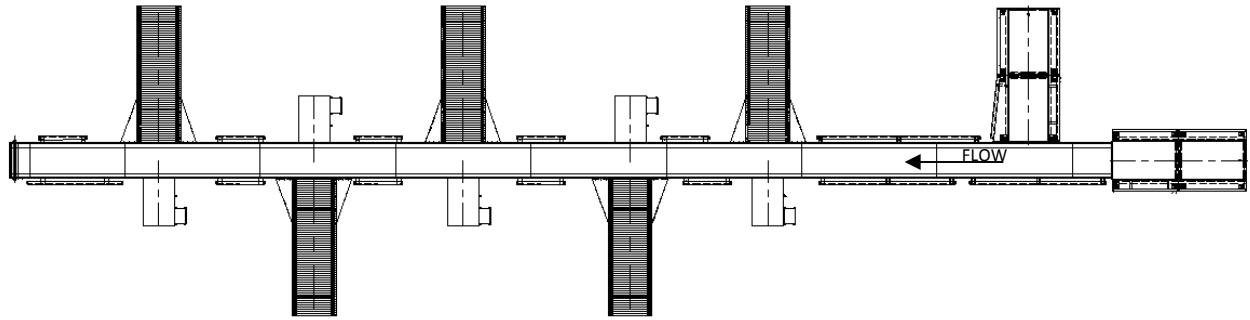

In-Line Configuration

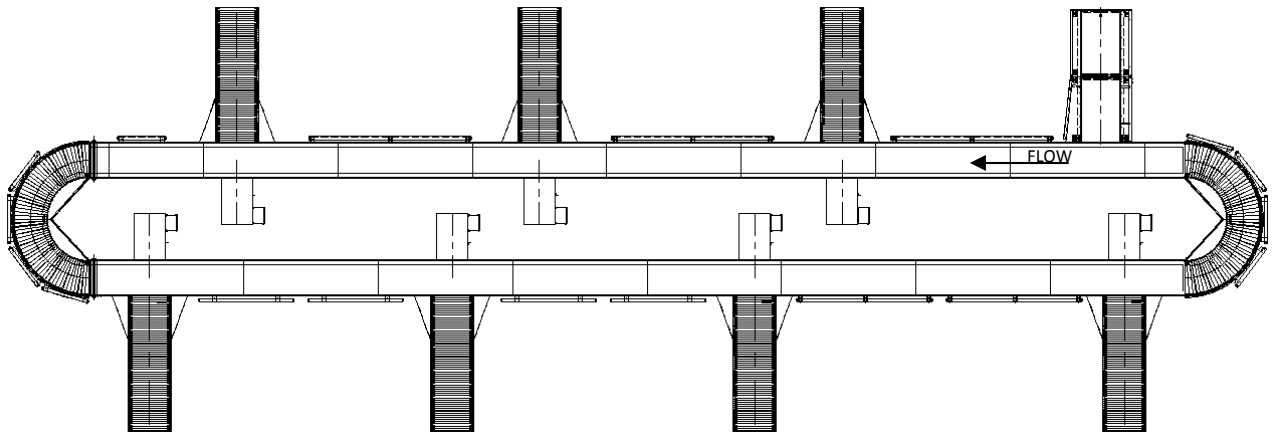

Recirculating Configuration

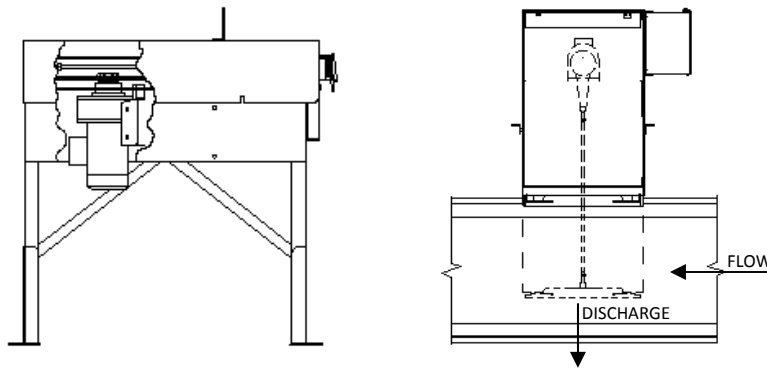

Pusher Diverter

