

# POWERED SPIRAL CONVEYOR

Powered Spiral Conveyor modules enables product to be transported from one elevation to the next in either accumulation or transportation mode. Powered Spiral Conveyor modules are designed in stackable, easy to handle and transport, single pitch modular sections reducing the time and cost of installation. The compact spiral footprint efficiently utilizes valuable floor space. Powered Spiral Conveyors use 24V MPR technology and are available in various configurations depending on customer requirements.

## Technical Data:

|   |   |  |
|---|---|--|
| <p><b>Widths:</b></p> <ul style="list-style-type: none"> <li>Between Frame (BF) of 15", 18", 24", 30", and 36" are available as a standard</li> <li>15" inside frame radius</li> <li>Additional Between Frame distances available upon request</li> </ul> | <p><b>Dimensions:</b></p> <ul style="list-style-type: none"> <li>17 ft maximum top of roller height with standard configuration</li> <li>21.5" inclination per winding with 6 degree incline angle as a standard</li> <li>Custom configurations available upon request</li> </ul> | <p><b>Rollers:</b></p> <ul style="list-style-type: none"> <li>1.9" diameter, 16 gauge galvanized, carrying rollers with 7/16" hex axles and tapered sleeves</li> </ul>   |
| <p><b>Drive Rollers:</b></p> <ul style="list-style-type: none"> <li>24 Volt DC brushless powered roller w/ tapered sleeve and external motor drive cards</li> <li>1.9" diameter, 7/16 hex axle</li> </ul>   | <p><b>Speed:</b></p> <ul style="list-style-type: none"> <li>Variable increments ranging from 55 to 237 feet per minute</li> </ul>   | <p><b>Load/Supports:</b></p> <ul style="list-style-type: none"> <li>100 lbs per linear foot as a standard</li> <li>Welded steel floor frame support supplied as a standard</li> <li>Contact NACI for larger load requirements</li> </ul> |
| <p><b>Frame:</b></p> <ul style="list-style-type: none"> <li>7-1/4" deep formed 12 gauge steel channel</li> <li>Powder coated NACI Blue as a standard</li> <li>Additional colors available upon request</li> </ul>   | <p><b>Controls/ Photo-Eyes:</b></p> <ul style="list-style-type: none"> <li>Spiral conveyors are provided complete with control cards, wiring/ cabling and photo-eye sensors</li> <li>All zones are wired with photo-eye sensors as a standard</li> </ul>                          | <p><b>Configurations:</b></p> <ul style="list-style-type: none"> <li>Accumulation Mode: Provides zero pressure non-contact accumulation</li> <li>Transportation Mode: Provides constant and continuous flow of product</li> </ul>        |

### Features:

- Reduced Installation Time
- Virtually Maintenance Free
- Durable Steel Frame
- Economical Design
- Reduced Footprint

### Applications:

- Station-to-Station
- Receiving
- Accumulation
- Storage
- Transportation

### Options:

- Clockwise or counterclockwise rotation
- Incline or Decline
- Custom Solutions

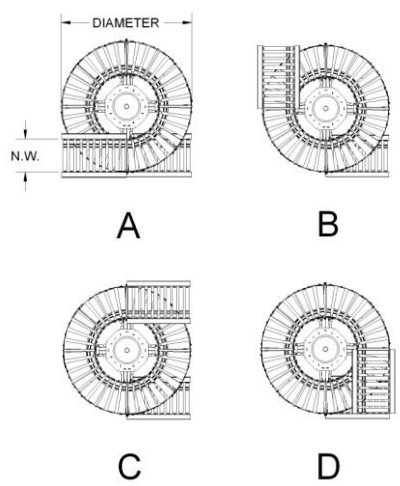
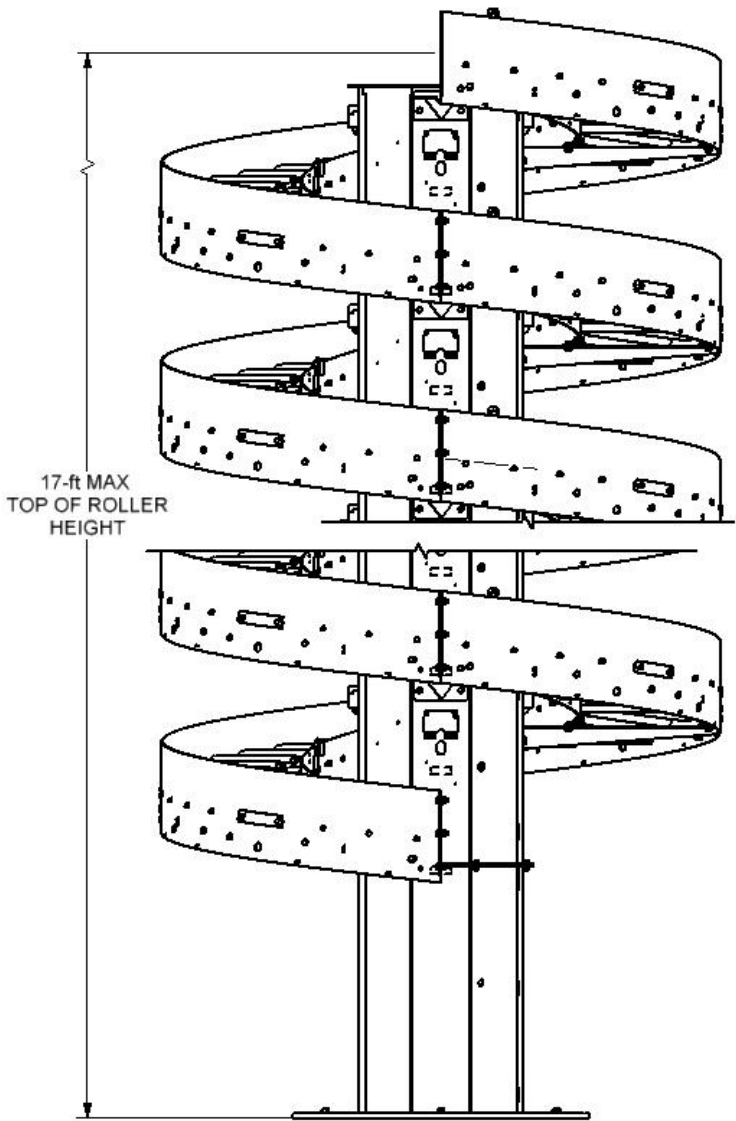

| N.W. | DIAMETER |
|------|----------|
| 15"  | 61"      |
| 18"  | 64"      |
| 24"  | 70"      |
| 30"  | 76"      |
| 36"  | 82"      |

